

INDUSTRY OF WASTE DISPOSAL

CABLES AND TEMPERATURE MEASUREMENT TECHNIQUE



Waste Incinerating plant Krefeld (D)

Flexible Cables



Compensating and extension cables

e.g. waste gas heat exchanger, high temperature facilities

- e.g. A 11 Lr (HTJ)
with fibre-glass braiding and steel wire armouring
- **Besilen® insulated compensating and extension cables**
with fibre-glass braiding and steel wire armouring
- **screened Besilen® insulated compensating and extension cables**
with Alu-foil screen or with overall copper screen
- **Fibre-glass insulated compensating and extension cables**
with fibre-glass braiding, SABtex braiding or steel wire armouring
- **PFA insulated extension cables**
with steel wire armouring and with stainless steel wire armouring
- **PFA insulated connection cables for resistance thermometers**
with fibre-glass braiding and stainless steel wire armouring



© Umweltschutzanlagen Siggewiesen



Cable track cables

**PUR cable track
data and control cables**

- **Data cables with coloured cores** 0,14 - 0,75 mm²
with reference to DIN 47100
- **Control cables with numbered cores** 0,50 - 50,0 mm²
e.g. S 200 / S 200 C / CC 500 P

SAB PUR cable track cables are particularly for continuously flexible use, e.g. in cable tracks, control or data cables installed on industrial robots, automation plants, robot devices, automation systems, mostly where very high flexibility, abrasion resistance, notch resistance, oil and chemical resistance are requested. The cables are suitable for permanent use with millions of bending cycles during multiple-shift operation. The cut resistant and low-adhesion PUR sheath guarantees higher service life and high efficiency.

SKES · D-VIERSEN · S 200 12 x 1,5 mm² CE

ES · D-VIERSEN · S 200 C 12 x 1,5 mm² CE



Festoon-cables

- Our festoon cables are used in
 - transport and crane systems
 - conveyor belts
 - waste incinerating plants



Stahl-Zentrum / HKM

Applications for the industry of waste disposal

Flexible Cables



© Umweltschutzanlagen-Spinnweiden



Besilen® Silicone Cables

e.g. sorting plants for glass,
metal, paper and plastic waste

- Besilen® - single conductor and sheathed cables with fibre-glass braiding and steel wire armouring
 - ZKBi
Besilen® - ignition cable gas torches
 - BiAF/GL
Besilen® - insulated strands with fibre-glass braiding
 - BiHF-J
Besilen® - insulated strands with Besilen® outer sheath also available with extremely notch resistant Besilen® - outer sheath
 - BiHFP-J
BiHF with steel wire armouring for mechanical protection



Control and connection cables

- PVC and PUR control and connection cables

PUR control and connection cables are particularly suitable for control devices, e.g. on machine tools, conveyor or assembly lines, transporting equipment and production lines. They can be used at high mechanical load for fixed installation or flexible application with free movement, without tensile load and mechanically guided movement in dry, damp and wet rooms. These cables are used wherever abrasion resistance, notch toughness, oil and chemical resistance are strongly requested.



© EGN



© EGN / Wimpfler



Reeling Cables

- Our reeling cables are used in
 - transport systems
 - hoisting devices
 - movable motors
 - farm vehicles with high mechanical stress
 - spring cable and motor cable reels

Flexible Cables / Temperature Measurement Technique

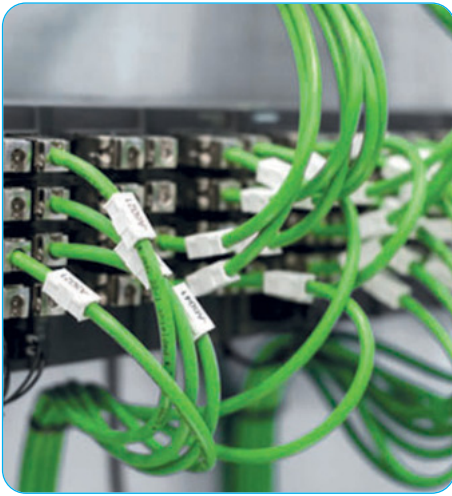

© eintracht / Fotolia



© EGN



Bus cables

- **CAN-bus cables**
CAN-bus cables are used for the exchange of digital information. Controller Area Network (CAN) for fast data transmission / exchange. Recommended as highly flexible data cables in cable tracks.
- **Profibus cables**
Application especially developed for the communication between automation systems and decentralized peripheral units in the field level. Transmission technology acc. to IEC 61158-2 fulfils the requests by chemical and petrochemical industries and also allows inherent safety and bus supply of field units. It is a bit synchronous data log with D.C. free transmission, often marked as H1. IEC 61158-2 technology is applied at Profibus-PA.
- **Profibus-DP cables/Profibus-FMS cables**
This Profibus modification, optimized with respect to velocity and low installation cost, was especially developed for the communication between automation systems and decentralized peripheral units. Profibus DP is used as a replacement for conventional parallel data transmission with 24 V or 0 - 20 mA. The specifications for Profibus-DP type A acc. to EN 50170 are met. Profibus-DP and Profibus-FMS apply the same transmission technology and a uniform bus access log. Therefore, both types can be used simultaneously on one cable.
- **Industrial Ethernet cables CAT 5, CAT 6, CAT 7**
Industrial Ethernet is a young and quickly developing network technology. Ethernet with the worldwide accepted TCP/IP (Transmission Control Protocol/Internet Protocol) will be the future connection to the well established field bus or sensor / actuator level. SAB Bröckskes developed a variety of cable solutions due to the strong innovative force of automation industry. Depending on the application, we are able to offer today CAT 5, CAT 6 and CAT 7 cable solutions for flexible and continuous flexible use, for and thermal stress as well as special cable constructions for reeling purpose and robot operation.



Thermo 8-plug and 16-plug connector T 065

- Thermocouples with standardized cable lengths can be easily connected. In case of failure, the defect element can be exchanged without much effort. The cables coming from the different measuring points can be plugged into the connector conveniently. Advantage: Reduced wiring effort. In general the application makes sense, whenever there are many measuring points and far distances that have to be overcome.



T 065 application range:

**Rust combustion plant
for waste
incinerating plant**

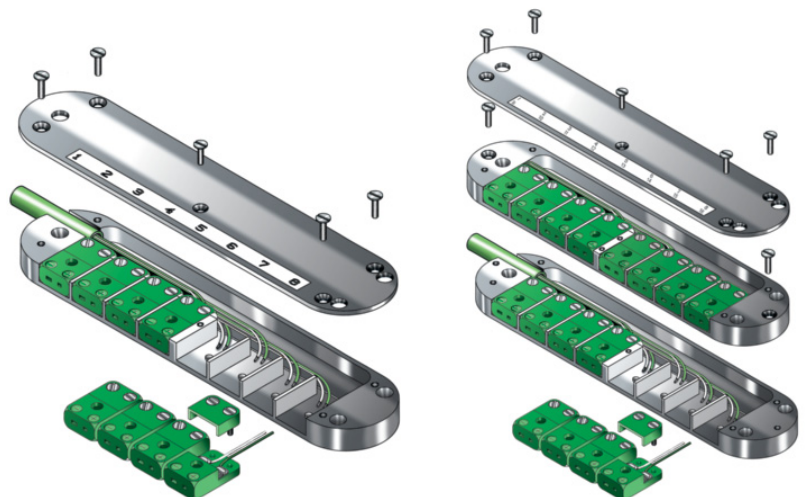

Temperature Measurement Technique



Mineral insulated thermocouples/ Mineral insulated resistance thermometers

- Mineral insulated thermocouples with fixed connecting cable
- Mineral insulated thermocouples with bare connection ends
- Mineral insulated thermocouples with thermo-plug/miniature plug
- Mineral insulated thermocouples with Lemosa connection element
- Mineral insulated thermocouples with connection head
- Mineral insulated thermocouples with connection head and screwed thread
- corresponding types as resistance thermometer



MTC 201 application range:

Waste
incinerating plants,
compost works

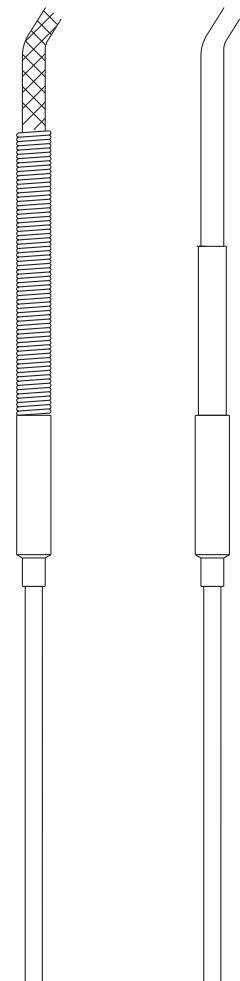

Temperature measurement probe for compost works

- **3 step probe as Pt 100**
The temperature probe has got three measuring points at three different levels so that the temperature can be collected three times. Furthermore, the gathered data can be transferred via radio sensor automatically. There is a better and quicker reaction on changing temperatures in the pile. As a consequence such a system is able to work more economically.



Temperature Measurement Technique



Protecting armatures and gauge slides

- Immersion protecting armatures
- Screwed protecting armatures
- Welding protecting armatures
- Flange protecting armatures
- Plug-in protecting armatures
- Resistance thermometer/gauge slides
- Thermocouple/gauge slides



T 427 application range:
Waste incinerating plants



T 435 application range:
Energy recycling



T 455 application range:
Sewage treatment plants



T 713 application range:
Waste incinerating plants,
special waste disposal

Temperature Measurement Technique



Straight thermocouples

■ Installation examples for straight thermocouples

Straight thermocouple are installed in combustion chambers, furnaces, conducts and closed channels of big dimensions. The type of measuring arrangement depends on the walls of the room through which the thermocouple is introduced into the chamber where the temperature has to be measured. With the help of a corresponding fixing device, the thermocouple can be either flange mounted or screwed in.

Straight thermocouples can be applied for temperature measurements between +200°C and +1600°C depending on the construction type with pressures up to max. 1 bar.



Application range:

Plants for special waste disposal



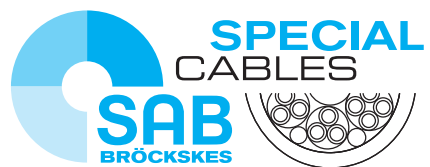

SAB Bröckskes GmbH & Co. KG

Grefrather Str. 204 - 212 b

41749 Viersen · GERMANY

Tel.: +49/2162/898-0

Fax: +49/2162/898-101

www.sab-cable.com

info@sab-cable.com